

# Zinc Weld On Anodes

## APPLICATION

Zinc has been used as a sacrificial anode material in seawater since 1824. Modern zinc anodes used for Cathodic Protection are cast from high purity zinc (99.99%) alloyed with aluminium and cadmium with limitations on the level of lead, iron and copper.

Typical applications include, submarine pipelines, ballast tanks, offshore structures, storage tank internals, quay walls, water tanks, marine applications and ships' hulls.

### Zinc Typical Hull Anode Alloy Composition

#### MIL-A-18001K

Elements	Minimum%	Maximum%
Al (Aluminium)	0.100	0.500
Cd (Cadmium)	0.025	0.070
Fe (Iron)	0	0.005
Cu (Copper)	0	0.005
Pb (Lead)	0	0.006
Other	0	0.100
Zn (Zinc)	99.314	0



CATHODIC  
PROTECTION  
CO LTD

# Zinc Weld On Anodes

## Zinc Weld On Hull Anode

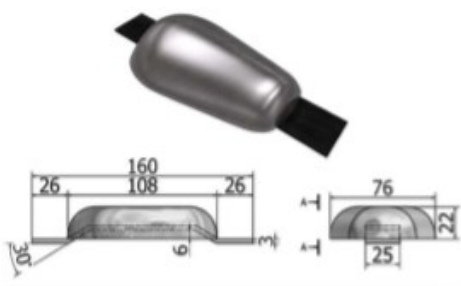

### MH9Z

0.9 Kg NET / 1 Kg GROSS

Zinc Weld On Hull Anode

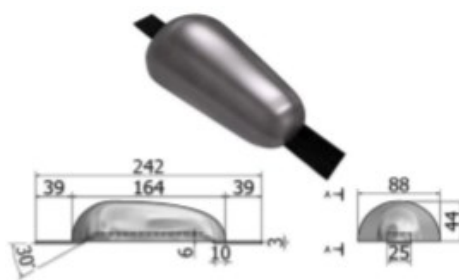

### MH20Z

2 Kg NET / 2.1 Kg GROSS

Zinc Weld On Hull Anode

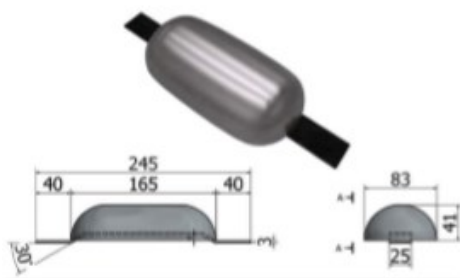

### MH28ZS

2.8 Kg NET / 3 Kg GROSS

Zinc Weld On Hull Anode

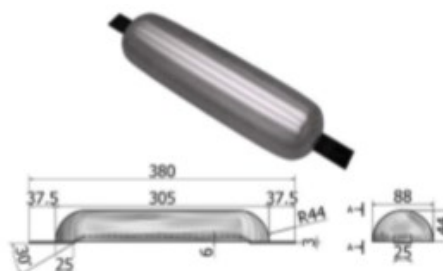

### MH28ZS

4.2 Kg NET / 4.5 Kg GROSS

Zinc Weld On Hull Anode



CATHODIC  
PROTECTION  
CO LTD

# Zinc Weld On Anodes

## Zinc Weld On Hull Anode

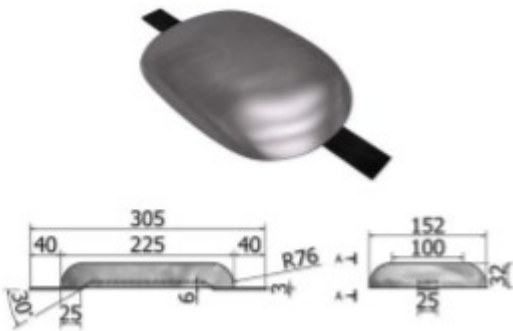

### MH58Z

5.8 Kg NET / 6 Kg GROSS

Zinc Weld On Hull Anode

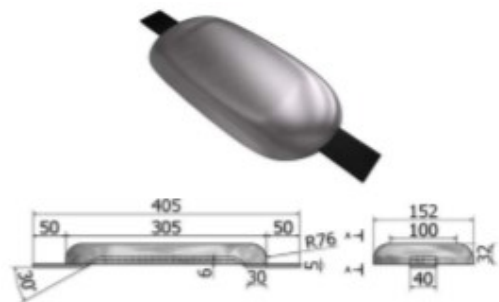

### MH73Z

7.3 Kg NET / 8 Kg GROSS

Zinc Weld On Hull Anode

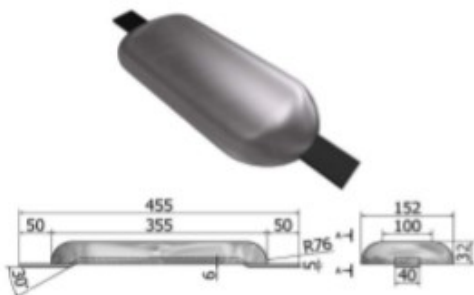

### MH94Z

9.4 Kg NET / 10 Kg GROSS

Zinc Weld On Hull Anode

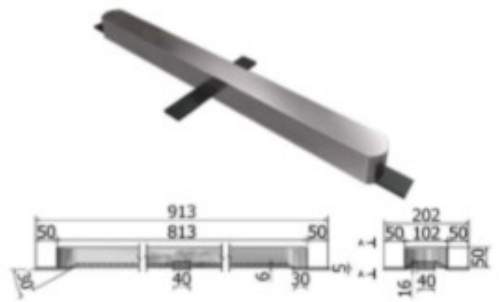

### MH95Z C/W CROSS STRAPS

9.5 Kg NET / 11 Kg GROSS

Zinc Weld On Hull Anode



CATHODIC  
PROTECTION  
CO LTD

# Zinc Weld On Anodes

## Zinc Weld On Hull Anode

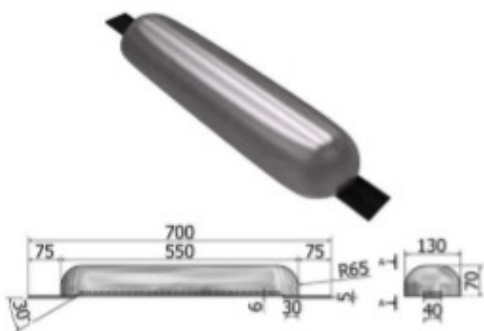

### MH110Z

11 Kg NET / 12 Kg GROSS

Zinc Weld On Hull Anode



### MH113Z

13 Kg NET / 12 Kg GROSS enough

Zinc Weld On Hull Anode

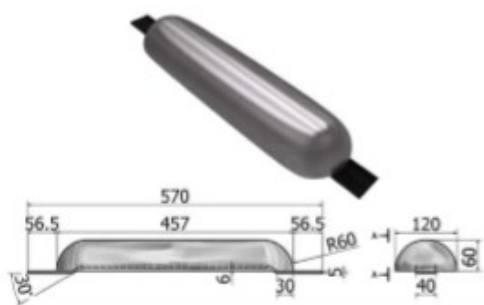

### MH130Z

13 Kg NET / 14 Kg GROSS

Zinc Weld On Hull Anode

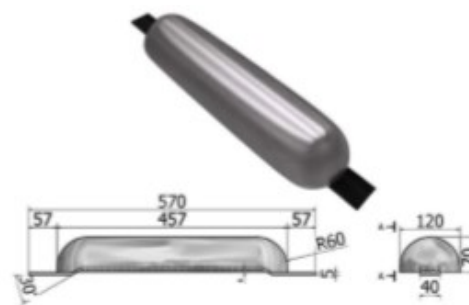

### MH140Z

14 Kg NET / 15 Kg GROSS

Zinc Weld On Hull Anode



CATHODIC  
PROTECTION  
CO LTD

# Zinc Weld On Anodes

## Zinc Weld On Hull Anode

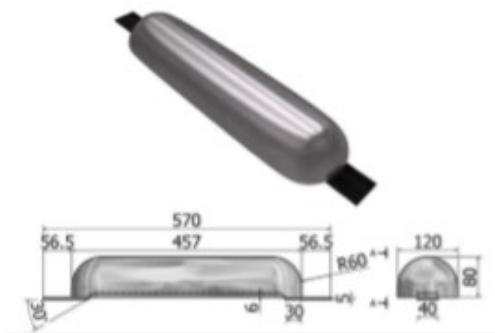

### MH155Z

15.5 Kg NET / 16.4 Kg GROSS

Zinc Weld On Hull Anode

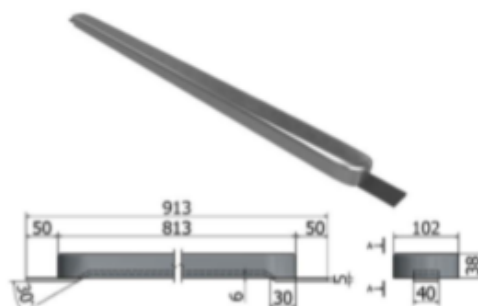

### MH180Z

18 Kg NET / 19.5 Kg GROSS

Zinc Weld On Hull Anode

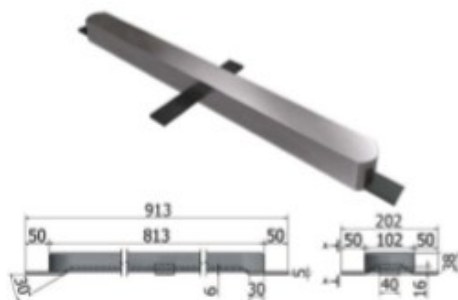

### MH180Z C/W CROSS STRAPS

18 Kg NET / 20 Kg GROSS

Zinc Weld On Hull Anode

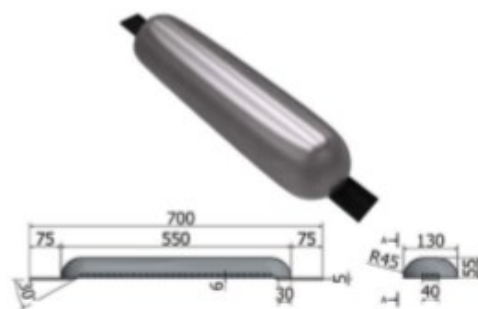

### MH190Z

19 Kg NET / 20 Kg GROSS

Zinc Weld On Hull Anode



CATHODIC  
PROTECTION  
CO LTD

# Zinc Weld On Anodes

## Zinc Weld On Hull Anode

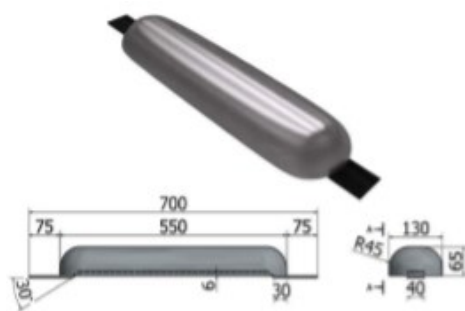

### MH140Z

24 Kg NET / 25 Kg GROSS

Zinc Weld On Hull Anode

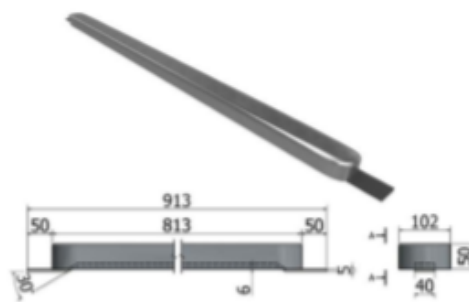

### MH250Z

25 Kg NET / 26.7 Kg GROSS

Zinc Weld On Hull Anode

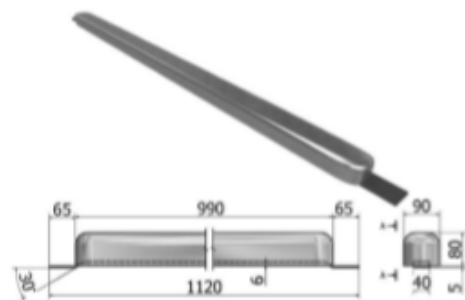

### MH480Z

48 Kg NET / 49.7 Kg GROSS

Zinc Weld On Hull Anode

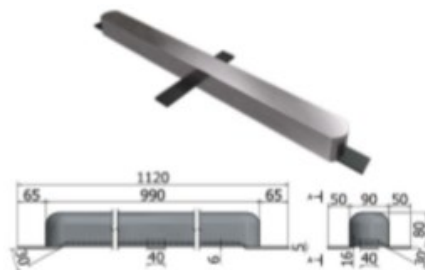

### MH480 C/W CROSS STRAPS

19 Kg NET / 20 Kg GROSS

Zinc Weld On Hull Anode