

Zinc Bolt On Anodes

APPLICATION

Zinc has been used as a sacrificial anode material in seawater since 1824. Modern zinc anodes used for Cathodic Protection are cast from high purity zinc (99.99%) alloyed with aluminium and cadmium with limitations on the level of lead, iron and copper.

Typical applications include, submarine pipelines, ballast tanks, offshore structures, storage tank internals, quay walls, water tanks, marine applications and ships' hulls.

Zinc Typical Hull Anode Alloy Composition

MIL-A-18001K

Elements	Minimum%	Maximum%
Al (Aluminium)	0.100	0.500
Cd (Cadmium)	0.025	0.070
Fe (Iron)	0	0.005
Cu (Copper)	0	0.005
Pb (Lead)	0	0.006
Other	0	0.100
Zn (Zinc)	99.314	0



CATHODIC
PROTECTION
CO LTD

Zinc Bolt On Anodes

Zinc Disc Anode

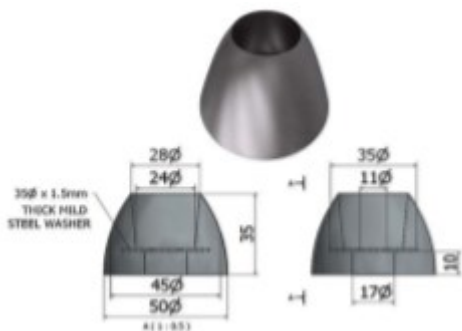

MD2.5Z

0.25 Kg NET / 0.3 Kg GROSS

Zinc Disc Anode

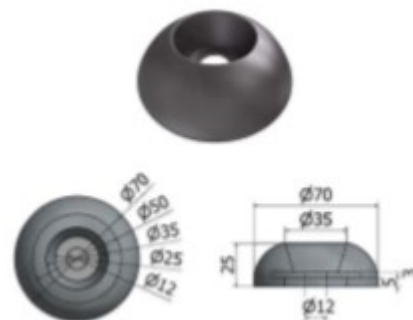

MD4Z

0.4 Kg NET / 0.8 Kg GROSS

Zinc Disc Anode

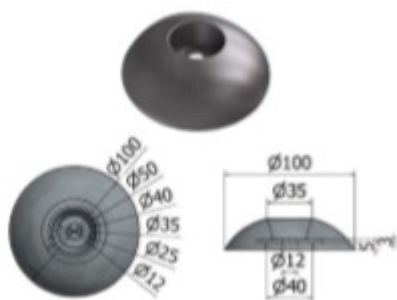

MD9Z

0.9 Kg NET / 1 Kg GROSS

Zinc Disc Anode

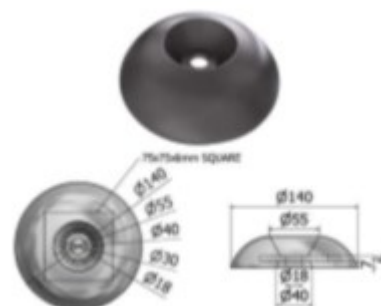

MD23Z

2.3 Kg NET / 5 Kg GROSS

Zinc Disc Anode



CATHODIC
PROTECTION
CO LTD

Zinc Bolt On Anodes

Zinc Bolt On Hull Anode

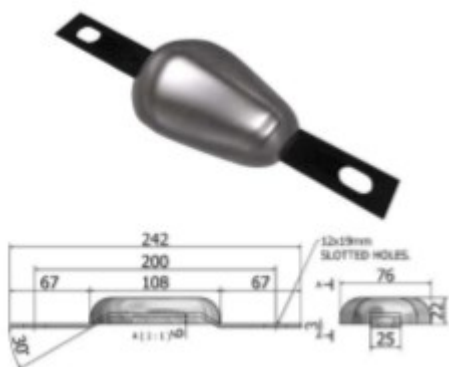

MH9ZS

0.9 Kg NET / 1 Kg GROSS

Zinc Bolt On Hull Anode

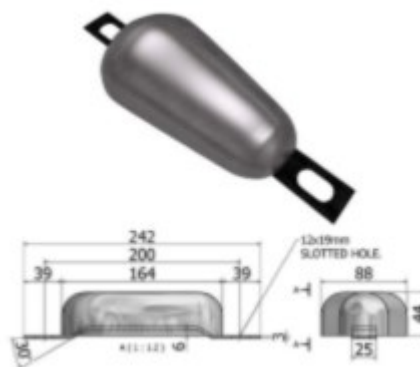

MH20ZS

2 Kg NET / 2.1 Kg GROSS

Zinc Bolt On Hull Anode

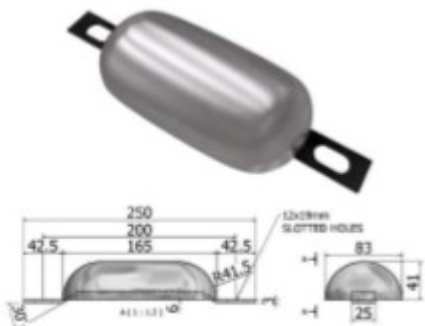

MH28ZS-1

2.8 Kg NET / 3 Kg GROSS

Zinc Bolt On Hull Anode

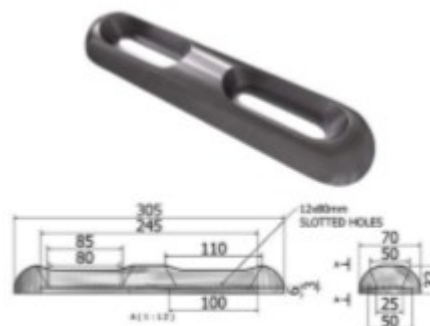

MH28ZS-2

2.8 Kg NET / 3 Kg GROSS

Zinc Bolt On Hull Anode



CATHODIC
PROTECTION
CO LTD

Zinc Bolt On Anodes

Zinc Bolt On Anode

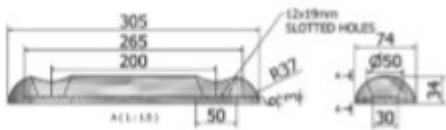

MH38ZS

3.8 Kg NET / 4 Kg GROSS

Zinc Bolt On Hull Anode

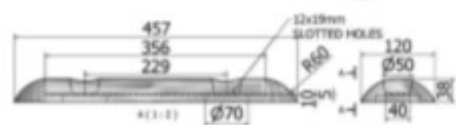

MH60ZS-1

6 Kg NET / 6.6 Kg GROSS

Zinc Bolt On Hull Anode

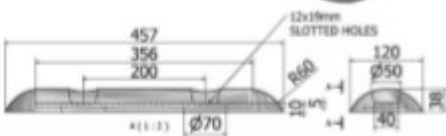

MH60ZS-2

6 Kg NET / 6.6 Kg GROSS

Zinc Bolt On Hull Anode

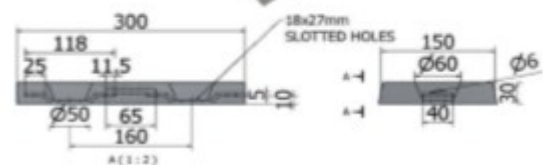

MH85ZS-CT

8.5 Kg NET / 9.2 Kg GROSS

Zinc Bolt On Hull Anode



CATHODIC
PROTECTION
CO LTD

Zinc Bolt On Anodes

Zinc Bolt On Hull Anode

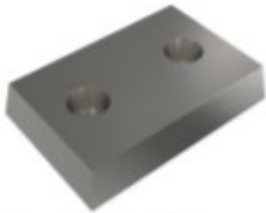

MH110ZS-CT

11 Kg NET / 12 Kg GROSS

Zinc Bolt On Hull Anode

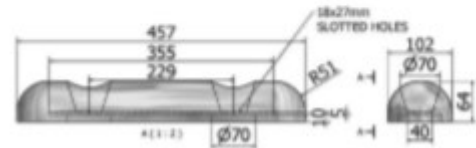

MH115ZS-1

11.5 Kg NET / 12 Kg GROSS enough

Zinc Bolt On Hull Anode

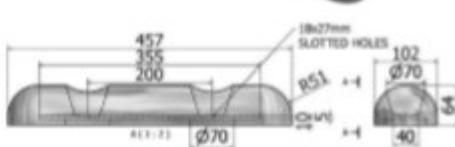

MH115ZS-2

11.5 Kg NET / 12 Kg GROSS

Zinc Bolt On Hull Anode

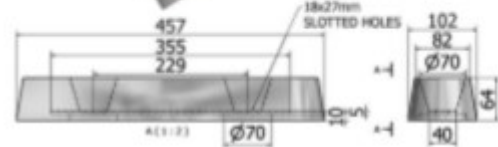

MH120ZS

12 Kg NET / 12.4 Kg GROSS

Zinc Bolt On Hull Anode



CATHODIC
PROTECTION
CO LTD

Zinc Bolt On Anodes

Zinc Bolt On Hull Anode

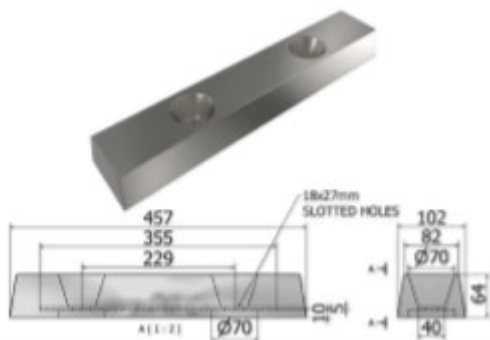

MH130ZS

13 Kg NET / 13.4 Kg GROSS

Zinc Bolt On Hull Anode

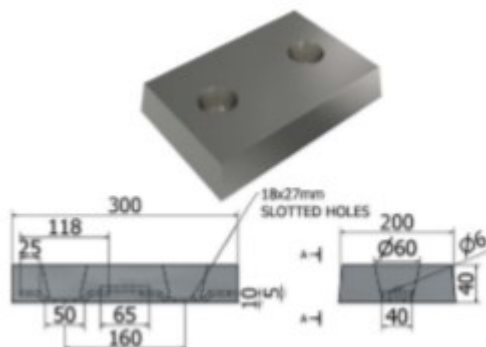

MH152ZS-CT

15.2 Kg NET / 16.2 Kg GROSS

Zinc Bolt On Hull Anode

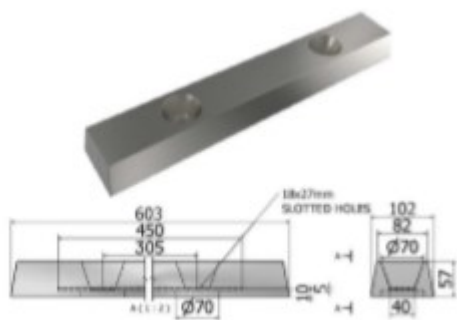

MH193ZS

19.3 Kg NET / 20 Kg GROSS

Zinc Bolt On Hull Anode



MH436ZS

43.6 Kg NET / 44.1 Kg GROSS

Zinc Bolt On Hull Anode