

# Aluminium Weld On Anodes

## APPLICATION

Aluminium alloy anodes have been formulated primarily for use in seawater. Alloys are also capable of achieving high output capacity in mud and brackish water of resistivity up to 150 Ohm.cm. Aluminium anodes have approximately three times the capacity of zinc alloys.

### Aluminium Typical Hull Anode Alloy Composition

#### DNV

Elements	Minimum%	Maximum%
Zn (Zinc)	2.500	5.750
In (Indium)	0.015	0.040
Si (Silicon)	0	0.120
Fe (Iron)	0	0.090
Cu (Copper)	0	0.003
Cd (Cadmium)	0	0.002

### Aluminium Typical Hull Anode Alloy Composition

#### G3

Elements	Minimum%	Maximum%
Zn (Zinc)	2.500	6.500
In (Indium)	0.015	0.200
Si (Silicon)	0	0.150
Fe (Iron)	0	0.120
Cu (Copper)	0	0.006
Others	0	0.020
Al (aluminium)	Remainder	



CATHODIC  
PROTECTION  
CO LTD

# Aluminium Weld On Anodes

## Aluminium Weld on Hull Anode

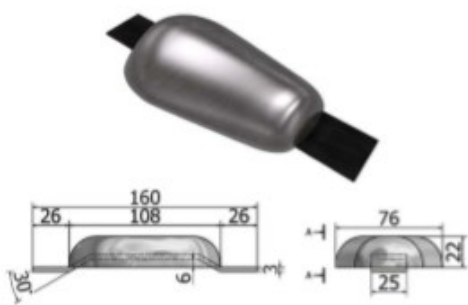

### MH3A

0.3 Kg NET / 0.4 Kg GROSS

Aluminium Weld On Hull Anode

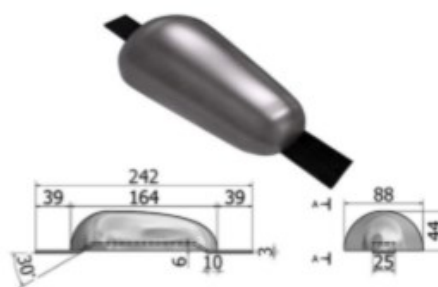

### MH8A

0.8 Kg NET / 1 Kg GROSS

Aluminium Weld On Hull Anode

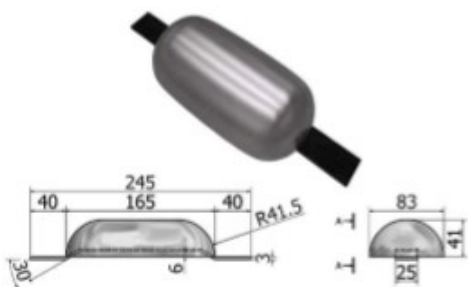

### MH11A

1.1 Kg NET / 1.3 Kg GROSS

Aluminium Weld On Hull Anode

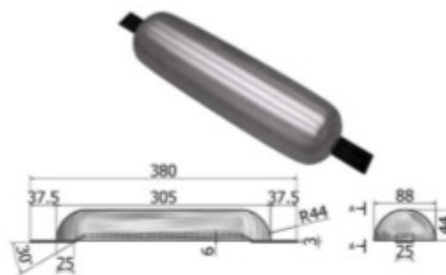

### MH18A

1.8 Kg NET / 2 Kg GROSS

Aluminium Weld On Hull Anode



CATHODIC  
PROTECTION  
CO LTD

# Aluminium Weld On Anodes

## Aluminium Weld on Hull Anode

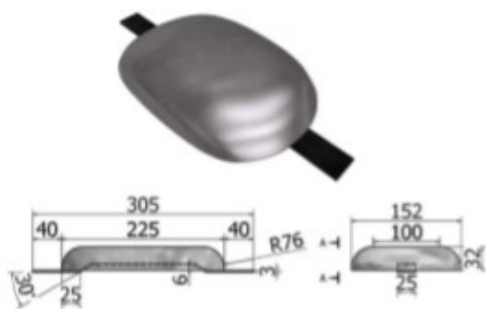

### MH25A

2.5 Kg NET / 2.8 Kg GROSS

Aluminium Weld On Hull Anode

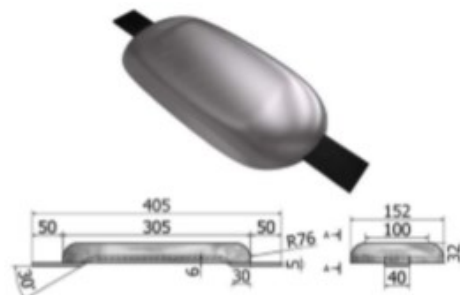

### MH30A

3 Kg NET / 3.5 Kg GROSS

Aluminium Weld On Hull Anode

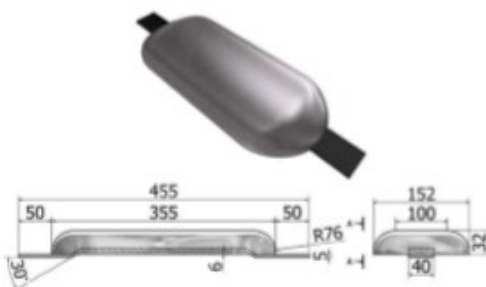

### MH40A

4 Kg NET / 4.5 Kg GROSS

Aluminium Weld On Hull Anode

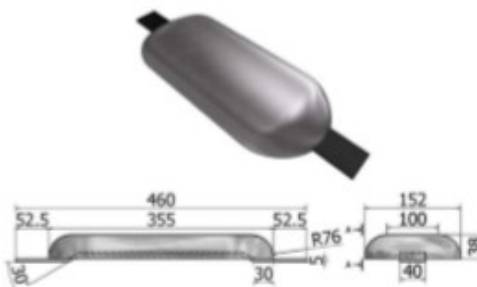

### MH45A

4.5 Kg NET / 5.2 Kg GROSS

Aluminium Weld On Hull Anode



CATHODIC  
PROTECTION  
CO LTD

# Aluminium Weld On Anodes

## Aluminium Weld on Hull Anode

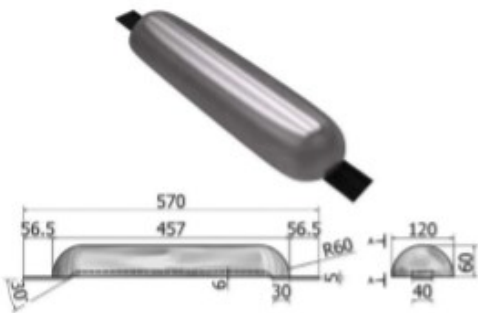

### MH50A

5 Kg NET / 6 Kg GROSS

Aluminium Weld On Hull Anode

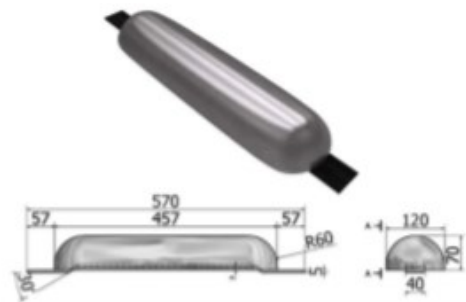

### MH56A

5.6 Kg NET / 6.5 Kg GROSS

Aluminium Weld On Hull Anode

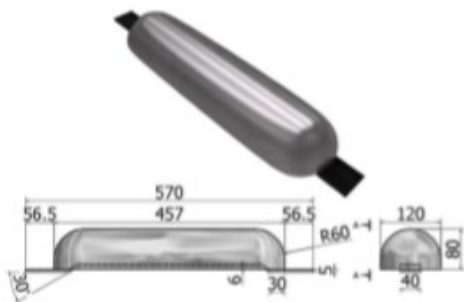

### MH60A

6 Kg NET / 7 Kg GROSS

Aluminium Weld On Hull Anode

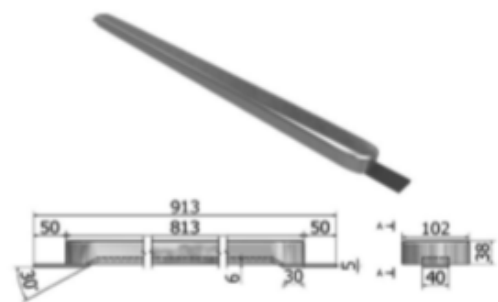

### MH70A-1

7 Kg NET / 8 Kg GROSS

Aluminium Weld On Hull Anode



CATHODIC  
PROTECTION  
CO LTD

# Aluminium Weld On Anodes

## Aluminium Weld on Hull Anode

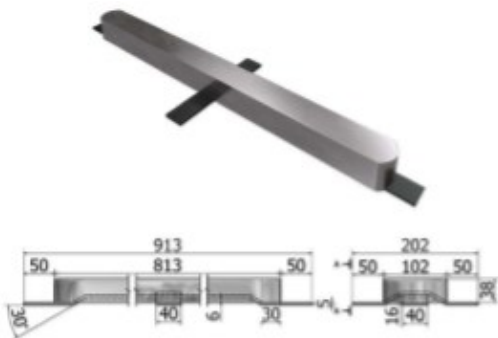

### MH70A C/W CROSS STRAPS

7 Kg NET / 8.8 Kg GROSS

Aluminium Weld On Hull Anode

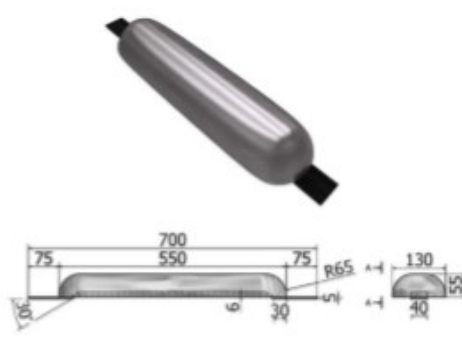

### MH80A

8 Kg NET / 9 Kg GROSS

Aluminium Weld On Hull Anode

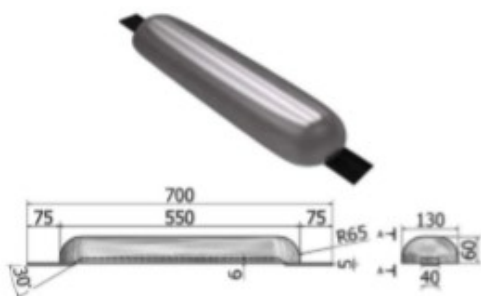

### MH90A

9 Kg NET / 10 Kg GROSS

Aluminium Weld On Hull Anode

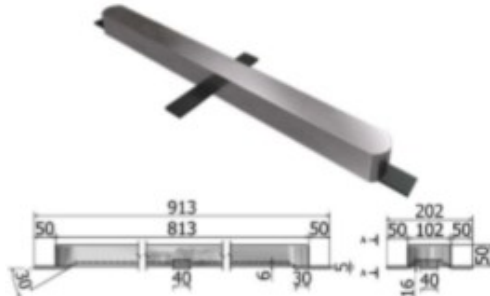

### MH95A C/W CROSS STRAPS

9.5 Kg NET / 11 Kg GROSS

Aluminium Weld On Hull Anode



CATHODIC  
PROTECTION  
CO LTD

# Aluminium Weld On Anodes

## Aluminium Weld on Hull Anode

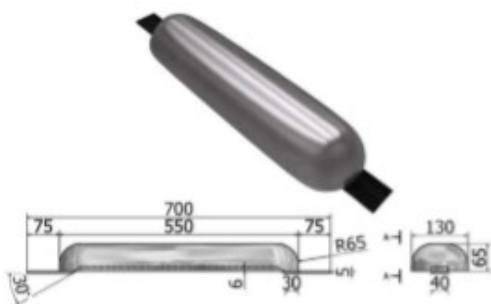

### MH100A

10 Kg NET / 11 Kg GROSS

Aluminium Weld On Hull Anode

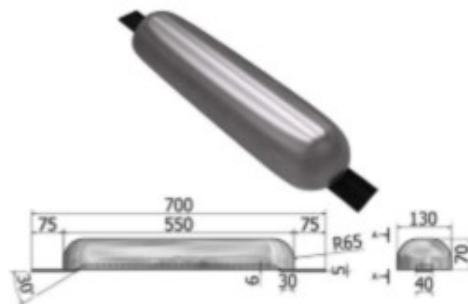

### MH110A

11 Kg NET / 12 Kg GROSS

Aluminium Weld On Hull Anode

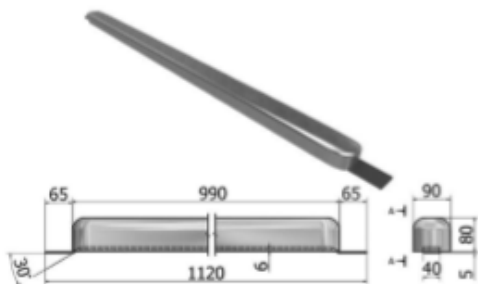

### MH190A

19 Kg NET / 20.5 Kg GROSS

Aluminium Weld On Hull Anode

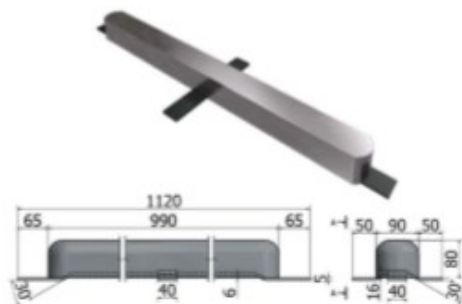

### MH190A C/W CROSS STRAPS

19 Kg NET / 21 Kg GROSS

Aluminium Weld On Hull Anode