

SECTION

1

GALVANIC CATHODIC PROTECTION

1.0 CONTENTS

1.1 Aluminium Anodes

- 1.1.1 Aluminium Tank Anodes
- 1.1.2 Aluminium Hull Anodes
- 1.1.3 Aluminium Platform / Jetty Anodes

1.2 Zinc Anodes

- 1.2.1 Zinc Tank Anodes
- 1.2.2 Zinc Hull Anodes
- 1.2.3 Zinc Platform Jetty Anodes
- 1.2.4 Zinc Ribbon Anodes

1.3 Magnesium Anodes

- 1.3.1 Magnesium Pipeline Anodes
- 1.3.2 Magnesium Ribbon Anodes





ALUMINIUM TANK ANODES

REVISION 1

APPLICATION

Aluminium alloy anodes have been formulated primarily for use in seawater. Alloys are also capable of achieving high output capacity in mud and brackish water of resistivity up to 150 Ohm.cm. Aluminium anodes have approximately three times the capacity of zinc alloys.

STANDARD TANK ANODE SIZES

Specification Code	Impalloy III
Fe	0.12% Max
Si	0.12% Max
Cu	0.006% Max
Zn	2.8 - 6.5%
In	0.01 - 0.02%
Ti	0.025% Max
Cd	0.002% Max
Others (each)	0.02% Max
Others (total)	0.05% Max
Aluminium	Remainder
Potential Ag/AgCl	-1.05 Volts
Max Capacity	2670 Amp.hours/kg

STANDARD TANK ANODE SIZES

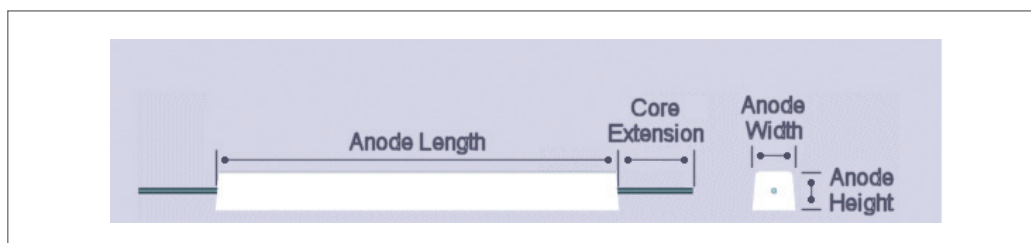

Anodes Type XT AT	Length (mm)	Core Extension (mm)	Width (mm)	Height (mm)	Core Diameter (mm)	Net Weight (kg)	Gross Weight (kg)
81	1197	227	51	51	12	8.1	9.6
102	1508	227	51	51	12	10.2	12.0
116	1225	227	60	60	12	11.6	13.1
132	1504	227	54	62	12	13.2	15.0
160	1478	227	64	64	12	16.0	17.7
188	1223	227	76	76	12	18.8	20.3



ALUMINIUM HULL ANODES

REVISION 1

APPLICATION

Aluminium alloy anodes have been formulated primarily for use in seawater. Alloys are also capable of achieving high output capacity in mud and brackish water of resistivity up to 150 Ohm.cm. Aluminium anodes have approximately three times the capacity of zinc alloys.

ALUMINIUM COMPOSITION

Specification Code	Impalloy III
Fe	0.12% Max
Si	0.12% Max
Cu	0.006% Max
Zn	2.8 - 6.5%
In	0.01 - 0.02%
Ti	0.025% Max
Cd	0.002% Max
Others (each)	0.02% Max
Others (total)	0.05% Max
Aluminium	Remainder
Potential Ag/AgCl	-1.05 Volts
Max Capacity	2670 Amp.hours/kg



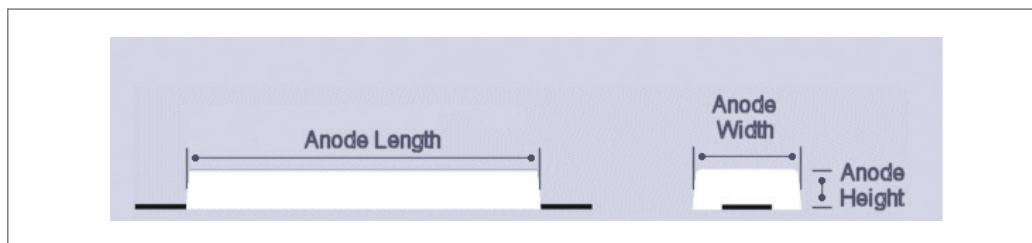







STANDARD HULL ANODE SIZES





ALUMINIUM HULL ANODES

REVISION 1

Anode Type AH	Overall Dimensions (mm)				Anode Body (mm)			Weights (kg)	
	View	Length	Width	Depth	Length	Width	Depth	Net	Gross
13AH		254	102	38	152	102	38	1.3	1.6
28AH		394	127	32	318	127	32	2.8	3.5
36AH		457	152	32	355	152	32	3.6	4.5
63AH		826	85	49	610	85	49	6.3	7.8
76AH		826	102	49	610	102	49	7.6	9.1
93AH		826	140	43	610	140	43	9.3	10.8
124AH		826	138	65	605	138	65	12.4	13.9
200AH		826	286	80	838	133	80	20.0	22.5
320AH		1422	152	64	1219	152	64	32.0	35.4
352AH		1435	175	65.5	1219	175	65.5	35.2	38.6



ALUMINIUM PLATFORM / JETTY ANODES

REVISION 1

APPLICATION

Aluminium alloy anodes have been formulated primarily for use in seawater. Alloys are also capable of achieving high output capacity in mud and brackish water of resistivity up to 150 Ohm.cm. Aluminium anodes have approximately three times the capacity of Zinc alloys.

ALUMINIUM COMPOSITION

Specification Code	Impalloy III
Fe	0.12% Max
Si	0.12% Max
Cu	0.006% Max
Zn	2.8 - 6.5%
In	0.01 - 0.02%
Ti	0.025% Max
Cd	0.002% Max
Others (each)	0.02% Max
Others (total)	0.05% Max
Aluminium	Remainder
Potential Ag/AgCl	-1.05 Volts
Max Capacity	2670 Amp.hours/kg

STANDARD JETTY / PLATFORM ANODE SIZES

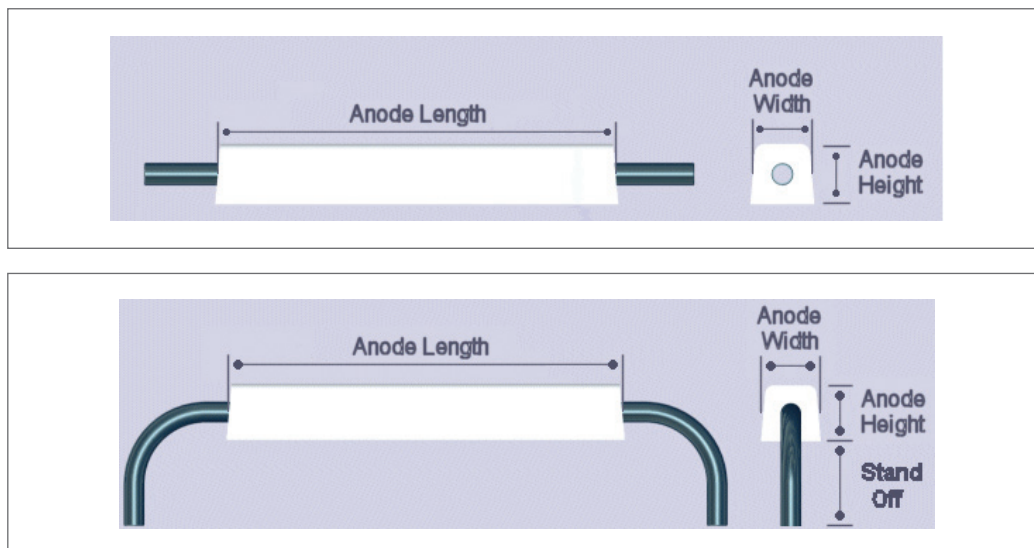



ALUMINIUM PLATFORM / JETTY ANODES

REVISION 1

Anode Type AP	Anode Length (mm)	Anode Width (mm)	Anode Height (mm)	Core Extension (mm)	Core Diameter (mm)	Net Weight (kg)	Gross Weight (kg)
350	1301	101	101	152	20	35	39.0
680	1515	133	127	152	20	68	72.5
1190	1526	184	159	152	20	119	126.0
1480	2373	160	162	152	60	148	167.9
2400	2622	210	210	152	114	240	305.6
3300	2372	252	244	152	114	330	390.0
4350	2910	254	257	152	114	435	507.1
5650	2973	283	283	152	114	565	638.5



ZINC TANK ANODES

REVISION 1

APPLICATION

Zinc has been used as a sacrificial anode material in seawater since 1824. Modern zinc anodes used for Cathodic Protection are cast from high purity zinc (99.99%) alloyed with aluminium and cadmium with limitations on the level of lead, iron and copper.

Typical applications include, submarine pipelines, ballast tanks, offshore structures, storage tank internals, quay walls, water tanks, marine applications and ships hulls.

ZINC COMPOSITION

Specification Code	US Mil Spec 18001 K
Cu	0.005% Max
Al	0.10 - 0.50%
Fe	0.005% Max
Cd	0.025 - 0.07%
Pb	0.006% Max
Others (total)	0.10% Max
Zn	Remainder
Potential Ag/AgCl	-1.05 + 0.05 V
Capacity	780 Amp.hours/kg Min

STANDARD TANK ANODE SIZES

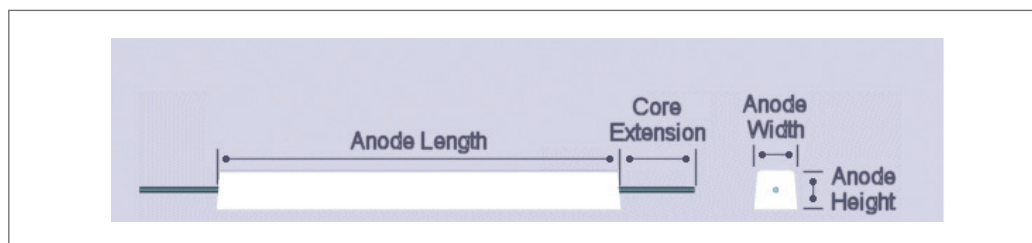

Anodes Type XT	Length (mm)	Core Extension (mm)	Width (mm)	Height (mm)	Core Diameter (mm)	Net Weight (kg)	Gross Weight (kg)
81	1197	227	51	51	12	8.1	9.6
102	1508	227	51	51	12	10.2	12.0
116	1225	227	60	60	12	11.6	13.1
132	1504	227	54	62	12	13.2	15.0
160	1478	227	64	64	12	16.0	17.7
188	1223	227	76	76	12	18.8	20.3



ZINC HULL ANODES

REVISION 1

APPLICATION

Zinc has been used as a sacrificial anode material in seawater since 1824. Modern zinc anodes used for Cathodic Protection are cast from high purity zinc (99.99%) alloyed with aluminium and cadmium with limitations on the level of lead, iron and copper.

Typical applications include, submarine pipelines, ballast tanks, offshore structures, storage tank internals, quay walls, water tanks, marine applications and ships hulls.

ZINC COMPOSITION

Specification Code	US Mil Spec 18001 K
Cu	0.005% Max
Al	0.10 - 0.50%
Fe	0.005% Max
Cd	0.025 - 0.07%
Pb	0.006% Max
Others (total)	0.10% Max
Zn	Remainder
Potential Ag/AgCl	-1.05 + 0.05 V
Capacity Ampere Hours	780 Amp.hours/kg Min



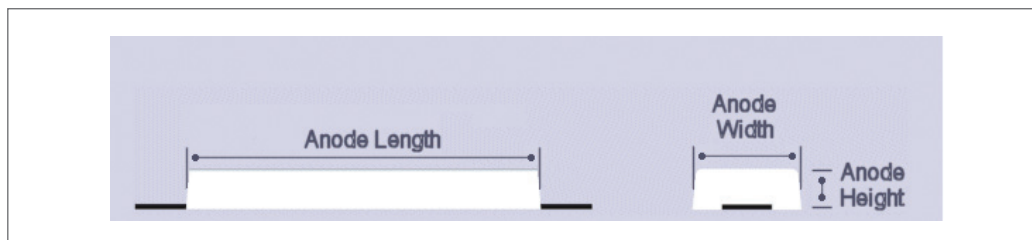





STANDARD HULL ANODE SIZES





ZINC HULL ANODES

REVISION 1

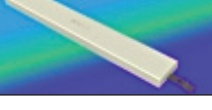
Anode Type XH	Overall Dimensions (mm)				Anode Body (mm)			Weights (kg)	
	View	Length	Width	Depth	Length	Width	Depth	Net	Gross
13XH		254	102	38	152	102	38	1.3	1.6
28XH		394	127	32	318	127	32	2.8	3.5
36XH		457	152	32	355	152	32	3.6	4.5
63XH		826	85	49	610	85	49	6.3	7.8
76XH		826	102	49	610	102	49	7.6	9.1
93XH		826	140	43	610	140	43	9.3	10.8
124XH		826	138	65	605	138	65	12.4	13.9
200XH		826	286	80	838	133	80	20.0	22.5
320XH		1422	152	64	1219	152	64	32.0	35.4
352XH		1435	175	65.5	1219	175	65.5	35.2	38.6



ZINC PLATFORM / JETTY ANODES

REVISION 1

APPLICATION

Zinc has been used as a sacrificial anode material in seawater since 1824. Modern zinc anodes used for Cathodic Protection are cast from high purity zinc (99.99%) alloyed with aluminium and cadmium with limitations on the level of lead, iron and copper.

Typical applications include, submarine pipelines, ballast tanks, offshore structures, storage tank internals, quay walls, water tanks, marine applications and ships hulls.

ZINC COMPOSITION

Specification Code	US Mil Spec 18001 K
Cu	0.005% Max
Al	0.10 - 0.50%
Fe	0.005% Max
Cd	0.025 - 0.07%
Pb	0.006% Max
Others (total)	0.10% Max
Zn	Remainder
Potential Ag/AgCl	-1.05 + 0.05 V
Capacity Ampere Hours	780 Amp.hours/kg Min

STANDARD JETTY / PLATFORM ANODE SIZES

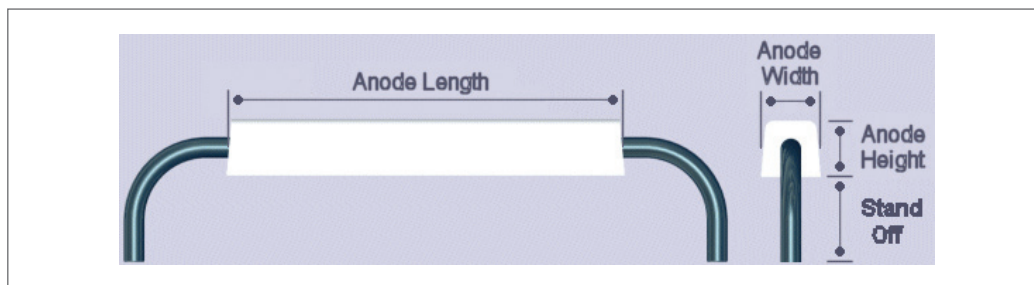
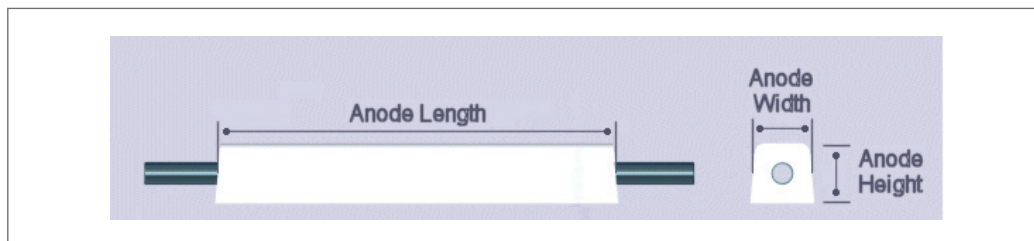



ZINC PLATFORM / JETTY ANODES

REVISION 1

Anode Type	Anode Length mm	Anode Width mm	Anode Height mm	Core Extension mm	Core Diameter mm	Net Weight kg	Gross Weight kg
99ZP	1033	35	40	152	6	9.9	10.2
142ZP	1482	35	40	152	6	14.2	14.6
500ZP	1492	70	70	152	12	50.0	51.6
652ZP	939	101	101	152	20	65.2	68.3
1086ZP	1564	101	101	152	20	108.6	113.2
1840ZP	1587	133	127	152	20	184.0	188.7
3160ZP	1569	184	159	152	25	316.0	323.2
5000ZP	2115	210	210	152	114	500.0	554.2



ZINC RIBBON ANODES

REVISION 1

APPLICATION

Zinc ribbon anodes provide a very simple, cost effective, maintenance-free method of corrosion control for buried or immersed metals such as iron, steel, aluminium, copper, etc. It is especially useful for unattended applications; those where other cathodic protection systems requiring monitoring and/or frequent maintenance cannot be possible. It can also be used as a temporary system prior to the installation of an impressed current system and as a method of providing AC mitigation.

TYPICAL USES

- External areas of steel pipe, especially in difficult environments such as below grade in rocky and mountainous terrain, thawed zones in permafrost, etc.
- Interior bottom areas of oil storage tanks where salt water settles out.
- Exterior bottoms of oil storage tanks.
- Interstitial spaces between old, corroded and new storage tank bottoms.
- In the limited space between inner and outer casings of wells of various kinds.
- For grounding steel tower footings of overhead power systems.
- To provide cathodic protection as well as to dissipate induced A.C. current on coated steel pipe.
- For personnel safety, as well as corrosion protection. To ground valves and test stations of pipe lines which are subject to induced A.C. current and fault currents.

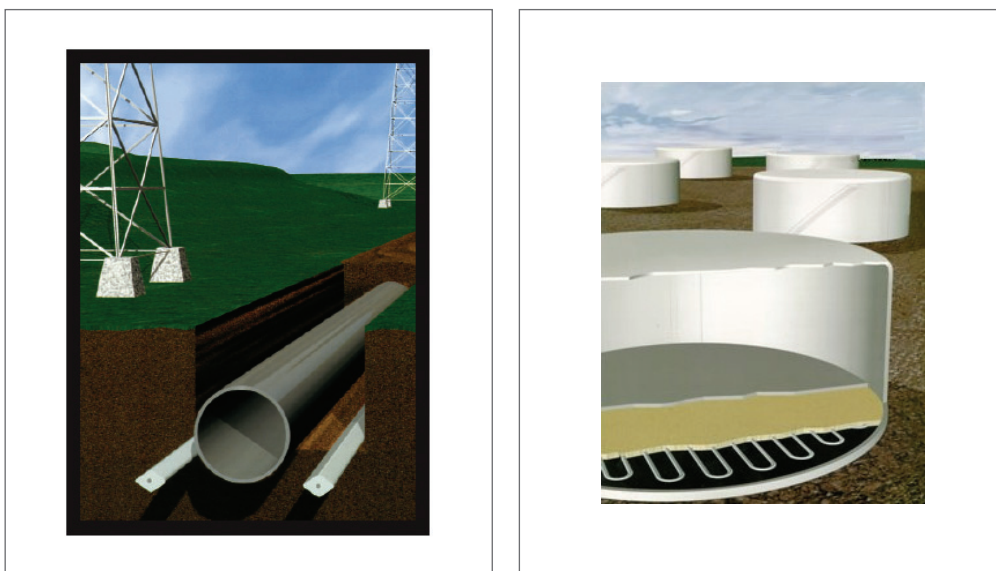

Typical installations on pipelines and tank bottoms



ZINC RIBBON ANODES



REVISION 1

ELECTROCHEMICAL PROPERTIES OF ZINC RIBBON ANODES	TYPE I	TYPE II
Open Circuit Potential (-V)*	1.05 min.	1.10 min.
Closed Circuit Potential (-V)*	1.00 min.	1.05 min.
Current Capacity (amp-hrs/lb)	819	819
Galvanic Efficiency (%)	95	90
Consumption-Actual (lb/amp•yr)	54.63	57.71

* wrt Ag/AgCl Reference Electrode

STANDARD SIZES AND TYPES AVAILABLE

Specification Chart				
Product Size	Super	Plus	Standard	Small
Cross Section:				
Inches	1"x1-1/4"	5/8"x7/8"	1/2"x9/16"	11/32"x13/32"
Millimeters	25.4x31.75	15.88x22.22	12.7x14.28	8.73x10.32
Weight/foot, Pounds ¹	2.4	1.2	0.6	0.25
Weight/kg., Meters	3.570	1.785	0.8925	0.372
Diameter of wire core ²				
Inches	0.185	0.135	0.130 ³	0.115
Millimeters	4.70	3.43	3.30	2.92
Standard Coil Length ⁴				
Feet	100 ⁺¹⁰ / ₋₀	200 ⁺²⁰ / ₋₀	500 ⁺³⁰ / ₋₀	1000 ⁺⁵⁰ / ₋₀
Meters	30.5 ⁺³ / ₋₀	61 ^{+6.1} / ₋₀	152 ⁺⁹ / ₋₀	305 ⁺¹⁵ / ₋₀
Standard Coil I.D.				
Inches	36	36	12	12
Centimeters	91.44	91.44	30.5	30.5
Packaging	Steel-banded random-wound open coils	Steel-banded random-wound open coils	Wood Reels	Wood Reels

¹All dimensions and weights are nominal.

²Galvanized steel.

³"Arctic" standard size has nominal core diameter of .163"

⁴Longer coil lengths are available on special order. Standard size also available in reels of 1000ft and 3600ft.



MAGNESIUM PIPELINE ANODES

REVISION 1

APPLICATION

Temporary protection of buried pipelines, protection of well coated buried pipelines, internal protection of water tanks, and protection of small marine structures, "Hot spot" locations for buried & submerged steel structures. Suitable for use in soils, mud, fresh water, brackish water and sea water.

MAGNESIUM ANODE DATA



MAGNESIUM ALLOY SPECIFICATIONS

	Standard	High Potential
Aluminium	5.30-6.70%	0.01% max
Zinc	2.50-3.50%	-
Manganese	0.15-0.70%	0.50-1.30%
Silicon	0.10% max	0.05% max
Copper	0.02% max	0.02% max
Nickel	0.002% max	0.001% max
Iron	0.003% max	0.03% max
Other impurities Each	-	0.05% max
Total	0.30% max	0.30% max
Magnesium	Balance	Balance
Open Circuit Potential wrt Cu/CuSO ₄	1.57-1.60 -Volts	1.77-1.82 -Volts
Closed Circuit Potential wrt Cu/CuSO ₄	1.52-1.57 -Volts	1.64-1.69 -Volts
Output Capacity	1200 A/hr/kg	1100 A/hr/kg
Current Efficiency	50%	50%

ANODE CABLE

Anodes are supplied with 5m of 1Cx6mm² XLPE/PVC cable (red outer sheath) as standard. Other sizes and lengths of cable can be fitted to suit customer requirements.



MAGNESIUM PIPELINE ANODES



REVISION 1

STANDARD ANODE TYPES AND WEIGHTS

Type	Nominal Weight (lbs)	Nominal Weight (lbs)	Approx Width (mm)	Approx Height (mm)	Approx Length (mm)
9	9	4.1	69.85	76.20	685.80
17	17	7.7	88.90	95.25	641.35
20	20	9.1	69.85	76.20	1,517.65
32	32	14.5	139.70	146.05	504.82
48	48	22.7	139.70	146.05	765.18
9P(*)	16.5	7.5	140	140	740
17P(*)	37.4	17	150	150	740
22P(*)	46.2	21	150	150	1700
32P(*)	70.4	32	195	195	640
48P(*)	96.8	44	195	195	900

(*) Packaged Anodes

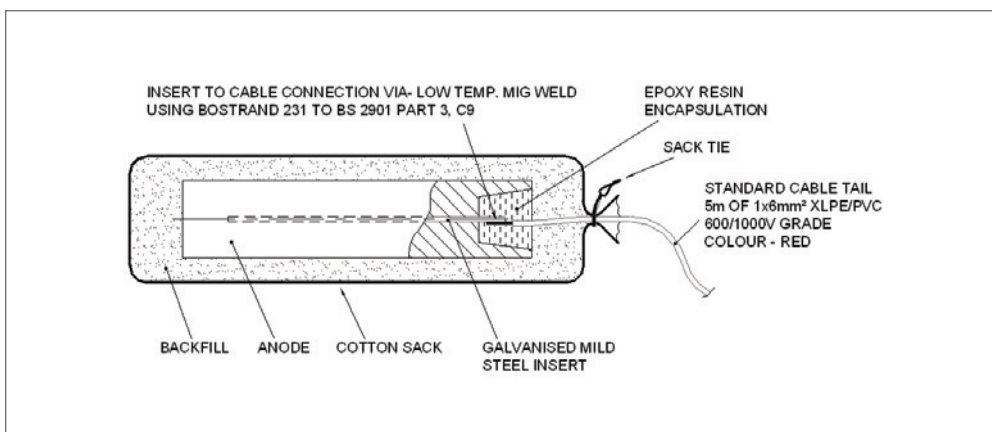

STANDARD BACKFILL

Gypsum	75%
Bentonite	20%
Sodium Sulphate	5%



MAGNESIUM RIBBON ANODES

REVISION 1

APPLICATION

Protection of well coated buried pipelines, internal protection of water tanks, pipeline casing sleeves. Suitable for use in soils & fresh water.

MAGNESIUM RIBBON DATA



MAGNESIUM ALLOY

	High Potential
Aluminium	0.01% max
Zinc	-
Manganese	0.50-1.30%
Silicon	0.05% max
Copper	0.02% max
Nickel	0.001% max
Iron	0.03% max
Other impurities Each	0.05% max
Total	0.30% max
Magnesium	Balance
Open Circuit Potential wrt Cu/CuSO ₄	1.77-1.82 -Volts
Closed Circuit Potential wrt Cu/CuSO ₄	1.64-1.69 -Volts
Output Capacity	1100 A/hr/kg
Current Efficiency	50%

Type	Nominal Dimensions	Nominal Wt (kg/m)
1000-MRBN	9.52mm x 19.05mm x305m	0.337

Continuous Steel Core : 3mm Diameter